

Double scissor foot pump operated lift table Kg. 350

Immagini Prodotto

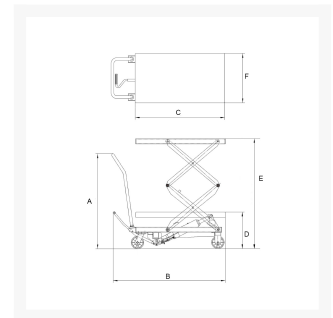

Descrizione

Capacity		kg	350
Maximum table height	E (h ₂)	mm	1300
Minimum table height	D (h ₁)	mm	370
Table platform size	CxFxthickness	mm	910x500x53
Wheels		mm	125x40
Overall length	B (L ₁)	mm	1210

Height of handle	h_3	mm	920
Stroke height	h_4	mm	930
Lifting speed (with load / without load)		mm/s	90/110
Lowering speed (with load / without load)		mm/s	100/90
Approximate lifting time to full height		s	10
Approximate lifting cycles with a single charge			100 ca.
Motor		W	800
4 sealed batteries			4x12V/15Ah
Battery weight		kg	18
Battery size	$l \times p \times h$	mm	100x150x100
In built charger		V/Ah	24/4
Weight		kg	160
IP protection class against water and dirt			IP54

Informazioni Aggiuntive

Cod. Prod.	PC350DE
GTIN/EAN	8053853155511
Fornito	Montato - Pronto all'uso
Weight kg	142.0000
Load Capacity	350
Type of Wheel:	-
Colour	Yellow RAL028
Manufacturer	Carmeccanica
Warranty	2 Years
Conformità	CE
Lead Time	Pronta Consegna