

Hand winch stacker with automatic friction brake, capacity Kg. 300

Immagini Prodotto

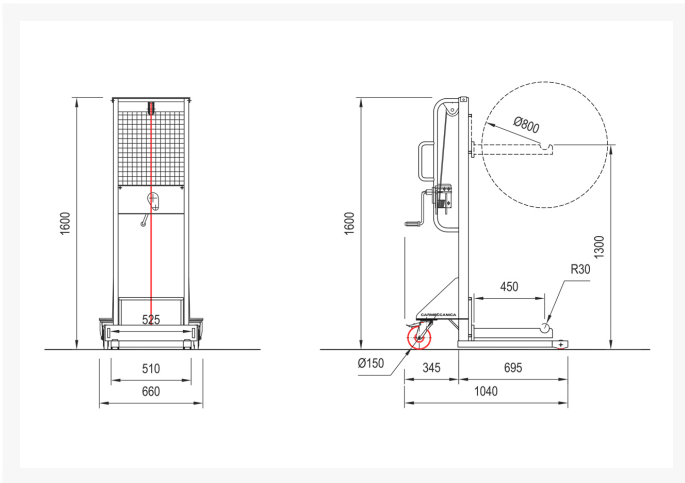



Descrizione

Capacity Kg 300

Weight Kg.56

Lifting height mm 1.580

Cable breaking load 1.000 kg

Push handles

Sizes:

Length mm 1.000

Total width mm 530

Minimum overall height mm 1.970
Maximum overall height mm 1.970
Length of fixed legs mm 600
Forks:
Length mm 600
Width mm 80
Thickness mm 50
Inner distance between forks mm 200
2 back wheels in Nylon/polyurethane Ø 150
1 with brake
2 Nylon front rollers Ø 80x40
Turning radius Wa mm 930
COMPLIANT TO CE RULES

Informazioni Aggiuntive

Cod. Prod.	ARX175
Fornito	Montato - Pronto all'uso
Weight kg	78.0000
Load Capacity	200
Diametro Ruota in mm	150
Type of Wheel:	Poliammide (Nylon)
Colour	Yellow RAL028
Manufacturer	Carmeccanica
Made in	Italia
Warranty	5 Years
Conformità	CE
Lead Time	Su Richiesta