

# Hand winch stacker with automatic friction brake, lifting height 1600 mm with loading plate

## Immagini Prodotto

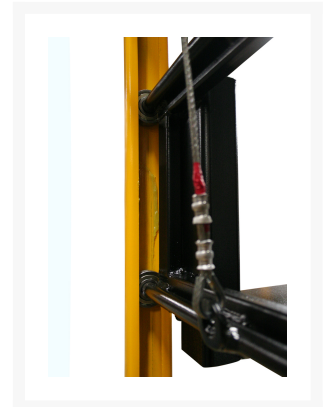
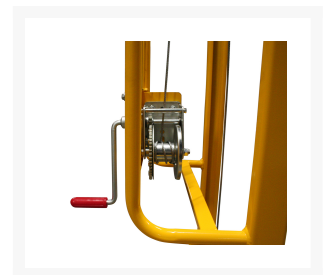

## Descrizione

---

Push handles

Hand winch 500 kg AL.KO with automatic friction brake

Textile cored 3 stranded rope with breaking load kg 1000.

The load can be lowered only through a direct operation on the hand winch

COMPLIANT TO CE RULES

### DESCRIPTION

Lifting system	Hand winch
Drive System	Pedestrian
Capacity	kg 200
Load axle to end forks	mm 500
Wheelbase	mm 670

### SIZES

Lift height	mm 1600
Lowered mast height	mm 1980
Raised mast height	mm 1980
Lowred lifting plate height	mm 60
Total length	mm 950
Length to face of forks	mm 335
Total width	mm 660
Loading plate length	mm 625
Loading plate width	mm 560
Loading plate thickness	mm 30
Ground clearance, centre of wheelbase	mm 15
Turning radius	mm 900
Height of push handles	mm 1200

### WEIGHT AND WHEELS

Weight	kg 56
--------	-------

Numbers of wheels	2/2
Front roller size	80x40
2 Rear casters with brakes	100x35
Tread front	mm 490
Tread rear	mm 500

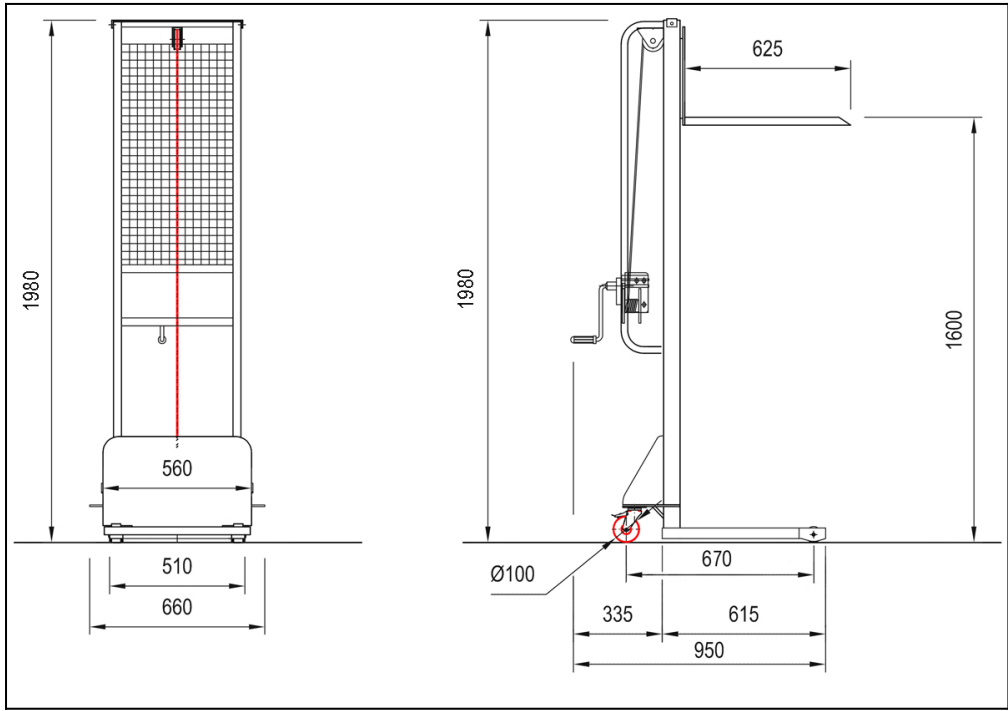

## Informazioni Aggiuntive

---

Cod. Prod.	ARX151
Fornito	Montato - Pronto all'uso
Weight kg	56.0000
Load Capacity	200
Colour	Yellow RAL028
Manufacturer	Carmeccanica
Made in	Italia
Warranty	5 Years
Conformità	CE
Lead Time	Su Richiesta