

Hand winch stacker with automatic friction brake, with loading plate

Immagini Prodotto

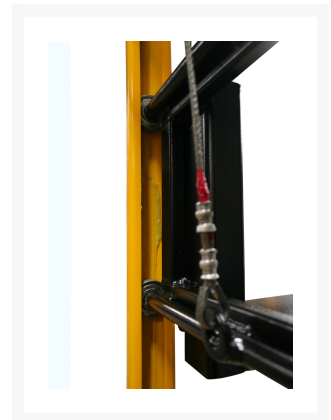

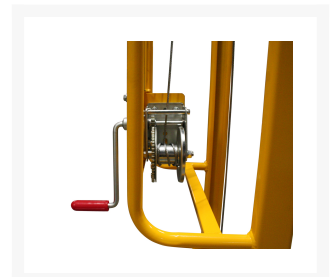
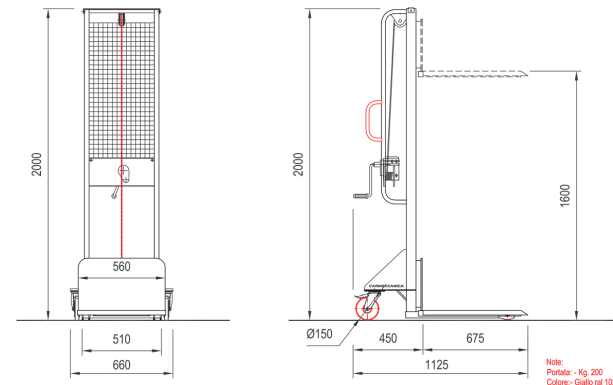

Descrizione

Push handle.

Certified hand winch with capacity 500 kg made by AL.KO with automatic clutch

Textile cored threestranded rope with breaking load kg 1000.

The lowering of the load can only occur if the operator turn the lever anti-clockwise

COMPLIANT TO CE RULES

DESCRIPTION

Rising system	Hand winch
Drive	Pedestrian
Capacity	kg 200
Load axle to end forks	mm 560
Wheelbase	mm 980

SIZES

Lift height	mm 1600
Height, fork lowered	mm 2000
Height, fork raised	mm 2000
Lowered plate height	mm 95
Overall length	mm 1125
Length to face of forks	mm 450
Total width	mm 660
Plate length	mm 675

Plate width x thickness	mm 510x30
Ground clearance, centre of wheelbase	mm 30
Inner distance between forks	/
Turning radius	mm 950
Height of push handles	mm 1200

WEIGHT AND WHEELS

Service weight	kg 56
number of wheels (front / rear)	2/2
Front rollers	80x40
Rear swivel casters (1 with brake)	150x45
Thread (front)	mm 450
Thread (rear)	mm 550

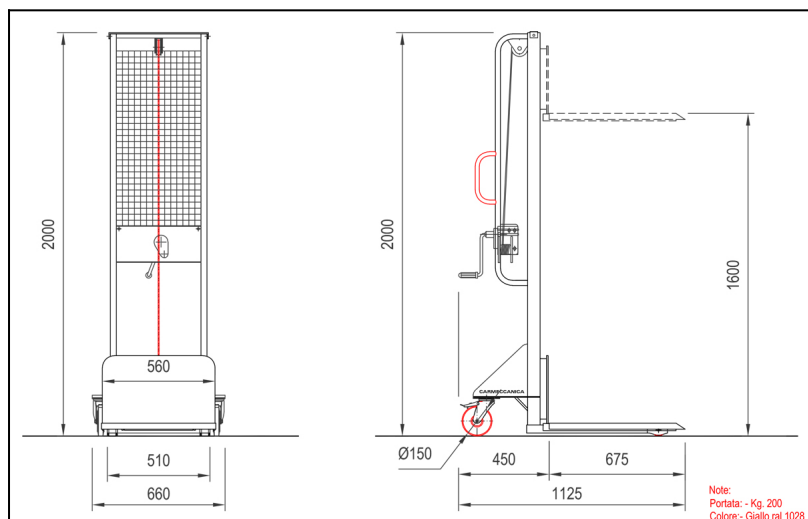

Informazioni Aggiuntive

Cod. Prod.	ARTARG2P
GTIN/EAN	8053853154910
Fornito	Montato - Pronto all'uso
Weight kg	56.0000
Load Capacity	200
Diametro Ruota in mm	150
Type of Wheel:	Nylon/Poliuretano
Colour	Yellow RAL028
Manufacturer	Carmeccanica
Made in	Italia
Warranty	5 Years
Conformità	CE
Lead Time	Pronta Consegna