

SELF PROPELLED PALLET TRUCK

Immagini Prodotto

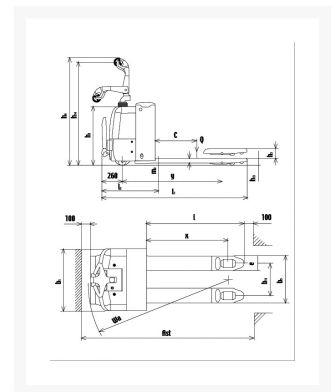

Descrizione

Self propelled pallet truck 2.000 Kg

TNBT20

FEATURES

Capacity	Q	Kg	2.000
Load center distance	C	mm	600
Drive system			Rider platform

SIZES

Lift height	h3	mm	120
Free lift		mm	-

Fork length	l	mm	1.150
Fork width	b5	mm	540
Fork width x thickness	e/s	mm	160/60
Overall length (rider platform closed)	l1	mm	1.815
Length to face of forks	l2	mm	665
Width	b1	mm	726
Minimum overall height	h1	mm	745
Maximum overall height	h4	mm	1.323
Turning radius	Wa	mm	1.640
Height of tiller in drive position MAX/min	h14	mm	1.320/940
Height of forks - lowered	h13	mm	85
Working aisle pallet 800x1200	AST	mm	2.105

PERFORMANCE DATA

Travel speed laden / unladen		Km/h	5.0/5.2
Lifting speed laden / unladen		mm/s	27/35
Lowering speed laden / unladen	y	mm/s	42/27
Gradeability laden / unladen		%	5 / 8

TELAIO

Tyres drive side / load side (M=driving wheel)		nr	2+1M/4
Poliurethane stabilizers		mm Ø	100x40
Driving wheel		mm Ø	230x75
Nylon front rollers		mm Ø	84x70
Wheelbase	y	mm	1.368
Tread. front	b10	mm	540
Tread rear	b11	mm	380

ELECTRIC MOTORS

Drive motor power s2 60min		Kw	1,5
----------------------------	--	----	-----

Lift motor power s3 15%	Kw	0,8
Drive controls		MOSFET
Battery	V/Ah	24/210
WEIGHT		
Service weight	Kg	520
Battery weight	Kg	185
CHARGER		
Charger	V-A	24-40

Informazioni Aggiuntive

Cod. Prod.	TNBT20
Fornito	Montato - Pronto all'uso
Weight kg	520.0000
Manufacturer	Carmeccanica
Made in	Italia
Warranty	2 Years
Conformità	CE
Lead Time	Esaurito